

MOUNTING INSTRUCTIONS

LHR 151-300kg

VER.05-2017EN

Fitting LHR 151-300kg for sectional doors in industry buildings where a minimum headroom height of 180mm available is.

The fitting set has the following characteristics:

- torsion spring set in front, on the lintel
- inner cable guiding
- required mounting space: sideroom 100mm, lintel headroom >180mm.

In this handbook we are mentioning the instructions for the correct installation of our track system. This handbook is dedicated to be used by experienced and qualified technicians and it's not advisable for handymen or for using by unschooled personnel.

The standard track system set consists of by following parts:

- A Set of rails (vertical and horizontal)
- B Necessary standard parts/ basic material for mounting
- C Fittings (hinges, wheels, etc.) from selected material.
- D Set of steel cables
- E Torsion shaft
- F Torsion springs.

Notice: Parts (bolts, etc.) required for mounting the tracks to the wall or for its hanging to the side wall or ceiling are not included.

Optional equipment

- * connecting/hanging profiles for horizontal rail set.
- * upper sealing for mounting on the lintel.

We are sure that you will successfully install the track system. When you will have some questions or you will need to clear up any problem please don't hesitate to contact Kružík Ltd.

ATTENTION!!

- ! **This handbook describes just the installation of the track system parts and it's necessary to complete it with instructions for the montage of any optional parts.**
- ! **Carefully read this handbook before beginning the installation.**
- ! **Some of the parts might be sharp or might have burrs. We recommend using protective gloves.**
- ! **All supplied parts are engineered for using with up-and-over doors.**
- ! **Through the tension of the springs heavy forces can impact. Work carefully. Use proper equipment. Ensure to stand in a stable position.**
- ! **Ensure enough lighting during the installation. Remove obstructions and dirt. Ensure that there is no one to assist except the mounters on the installation place. Other persons (children) can restrain the installation and they could threaten themselves.**

Equipment necessary for correct and fast installation

Electric tools	Tools	
Drilling machine	combination wrench 10, 13, 14, 15, 17mm	air level
Impact drilling machine	spanner 10, 13, 17	yardstick
Cordless drill	set of allen keys	knife
angle grinder	nut 10, 13mm + prolonged bits adapter	pencil
	combination pliers, waterpump pliers	2x bar for spring tensioning
	hammer	rope
		clamps

The construction conditions on the site are for sectional private and industrial doors installation and their further flawless operation essential!

- surface flatness
- for the sectional door installation the surface has to be even (side room, headroom, floor). Side walls and lintel have to run in one line. Maximal allowed flatness variations are +/-2 mm.
- masonry base for installation has to be solid and dry. In the mounting area is no electric wiring within the walls allowed.
- each larger unevenness of the mounting base, can have a negative influence on the proper door operation. Use appropriate fastening components to fix the sectional doors to the masonry wall.

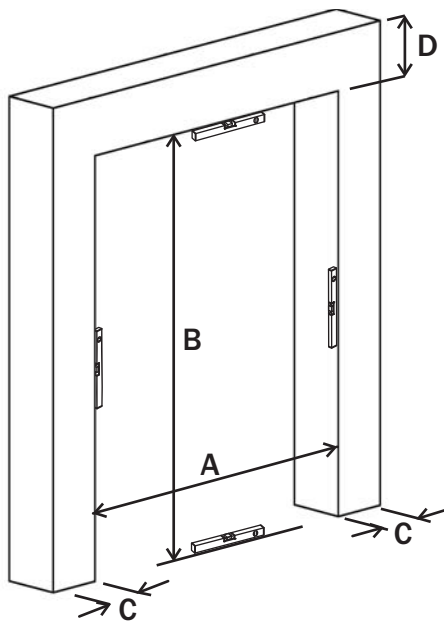
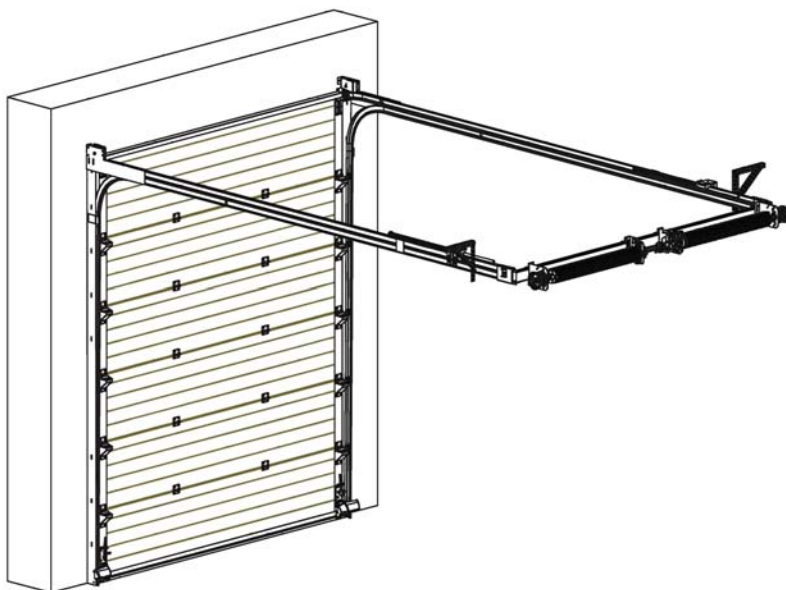

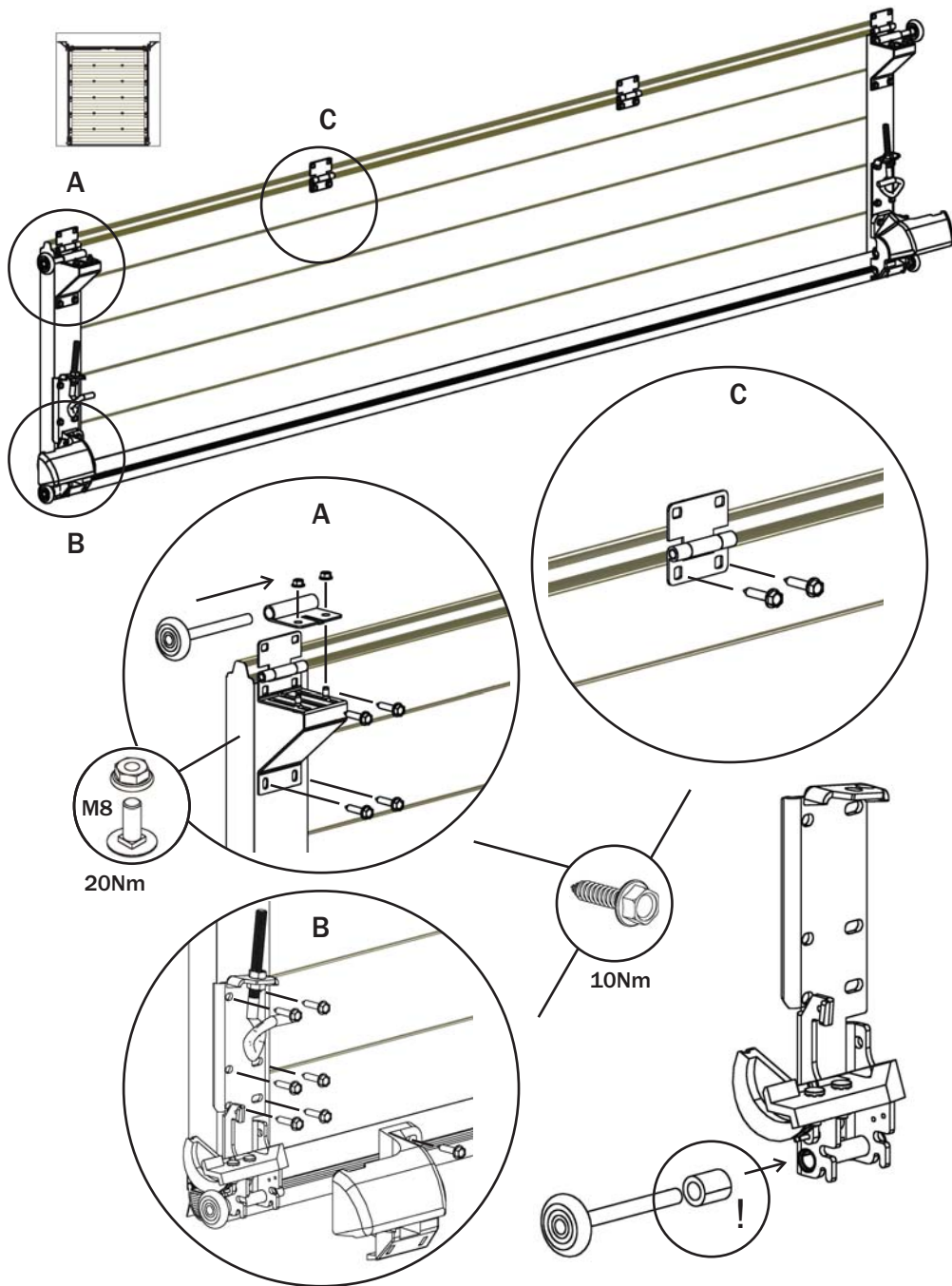

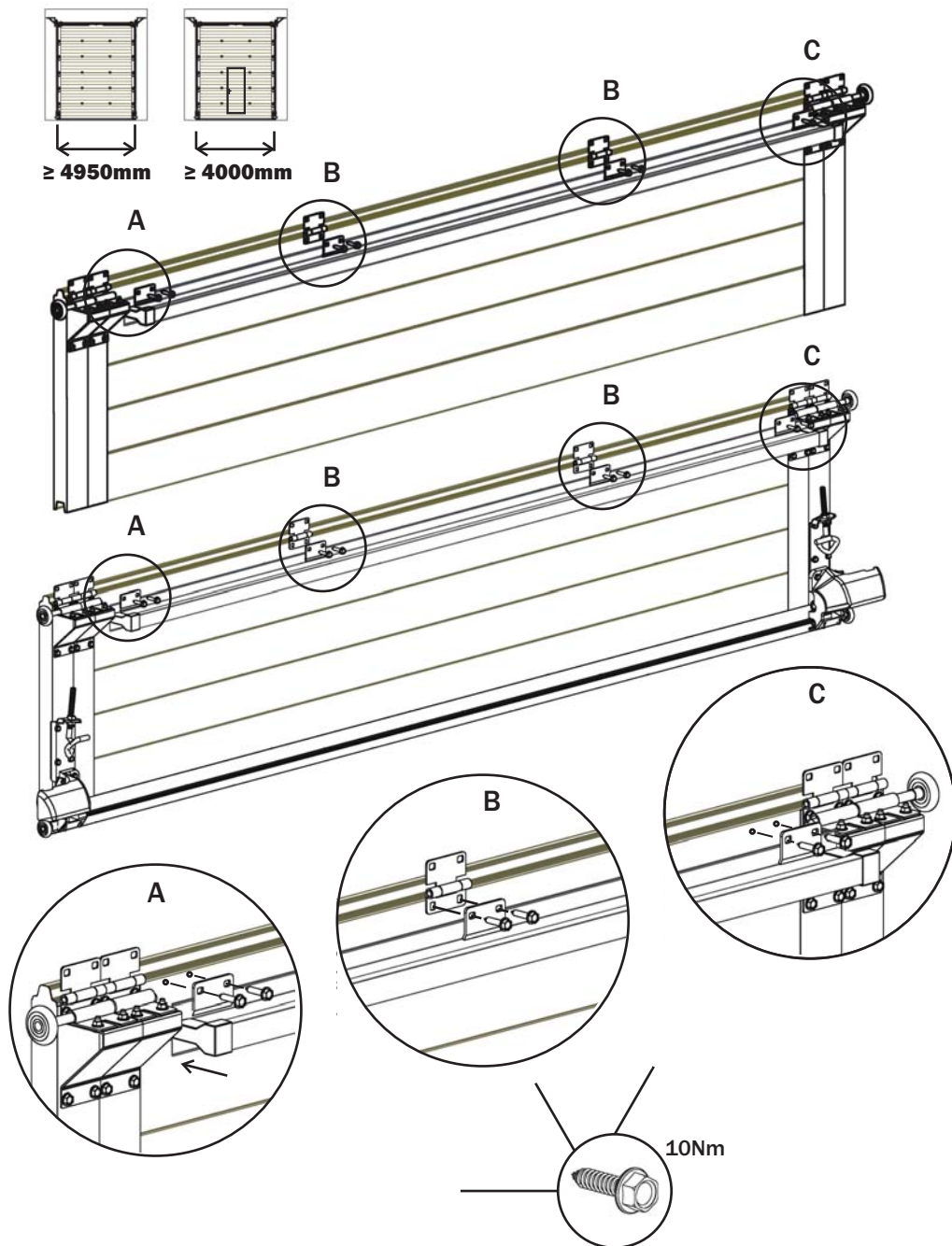

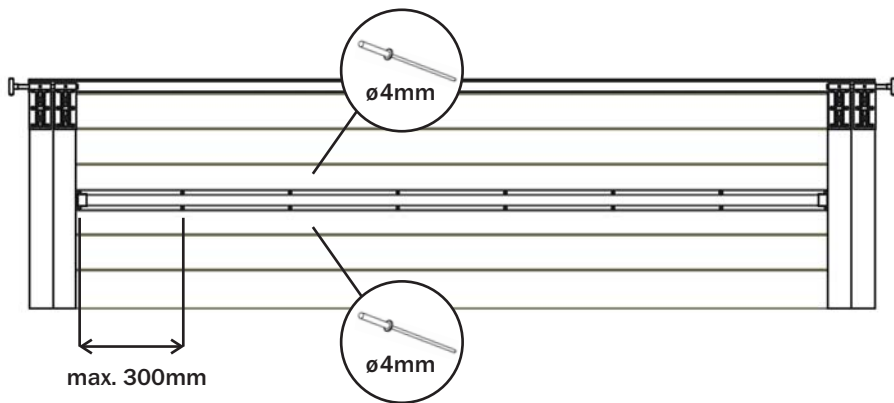
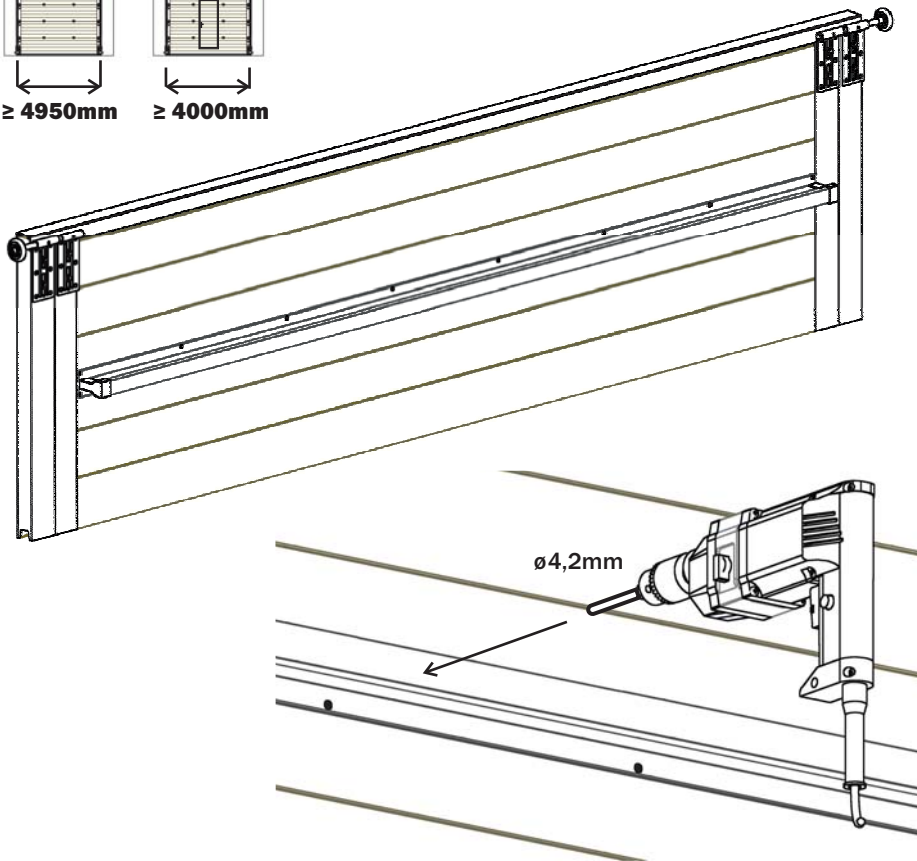
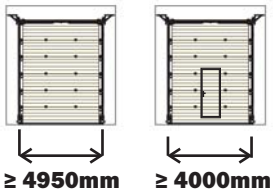

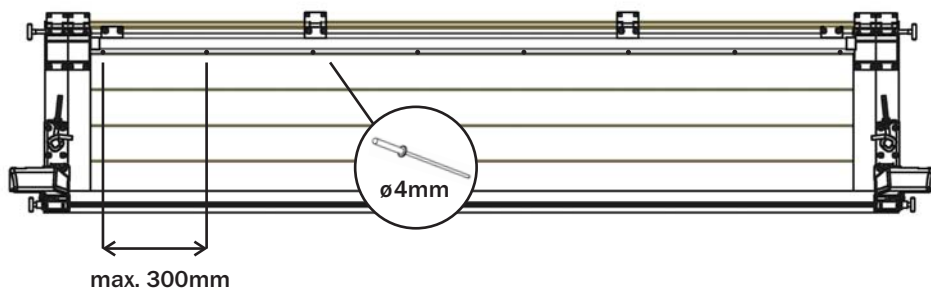
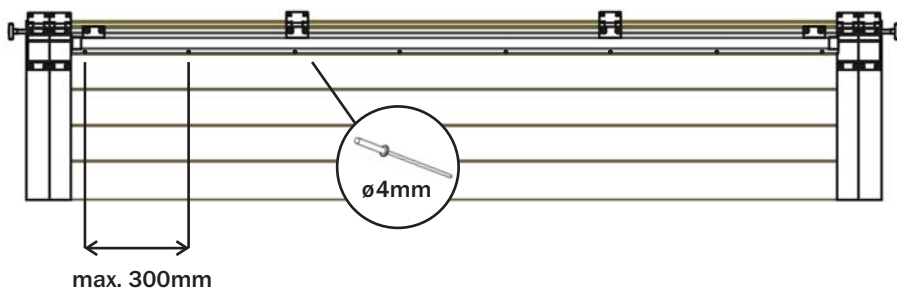
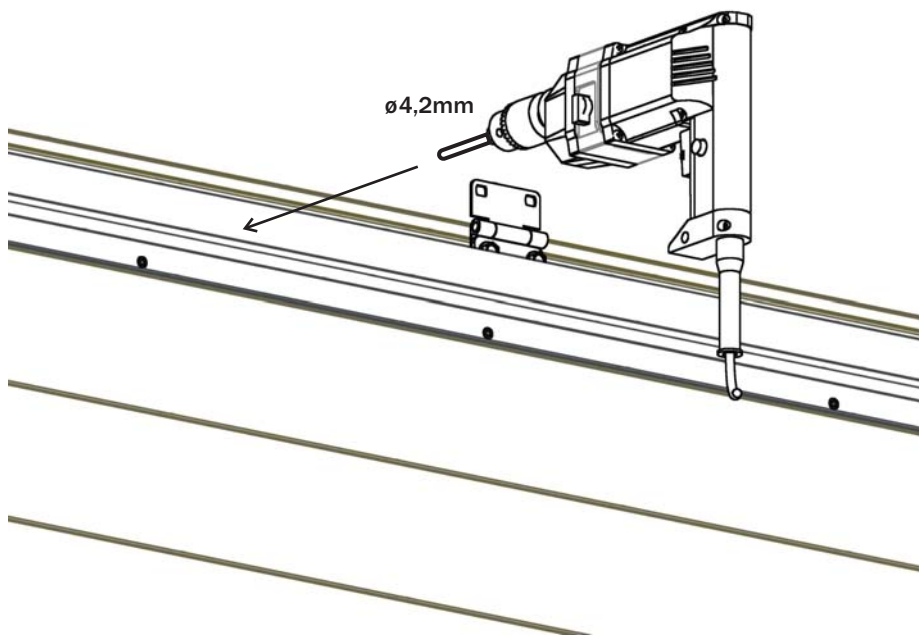

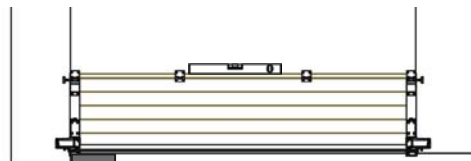
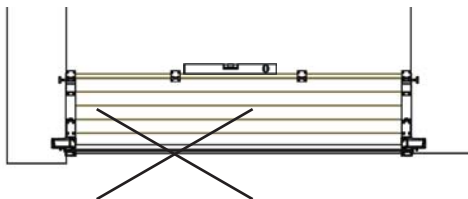
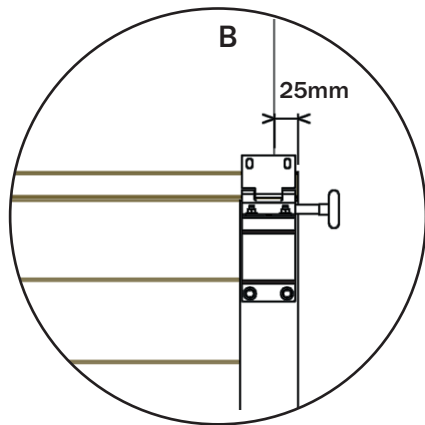
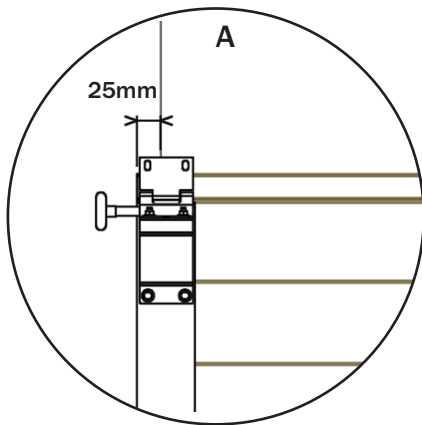
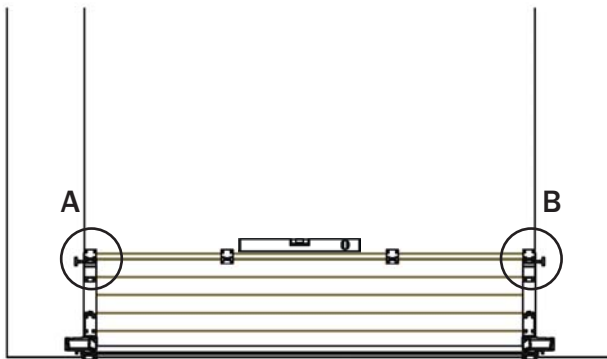

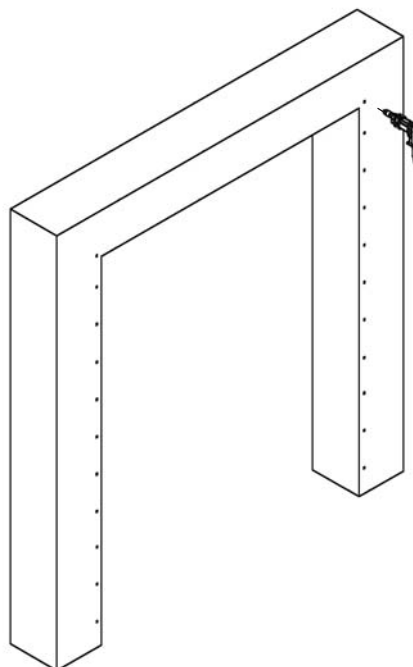
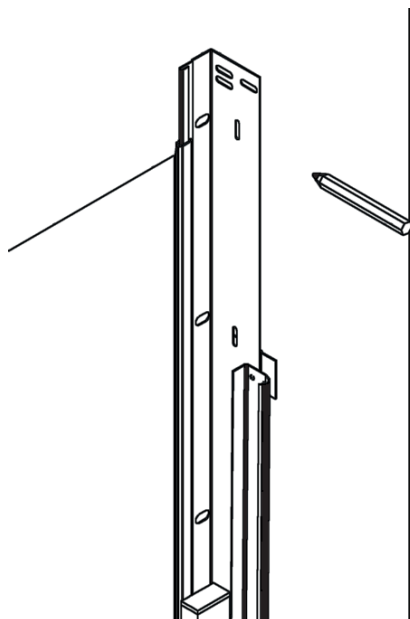
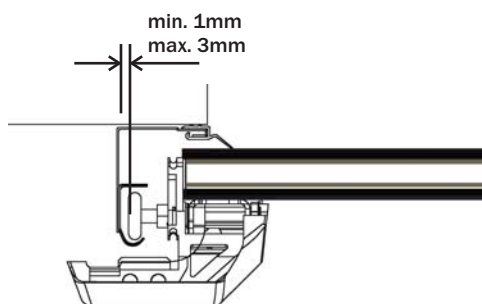
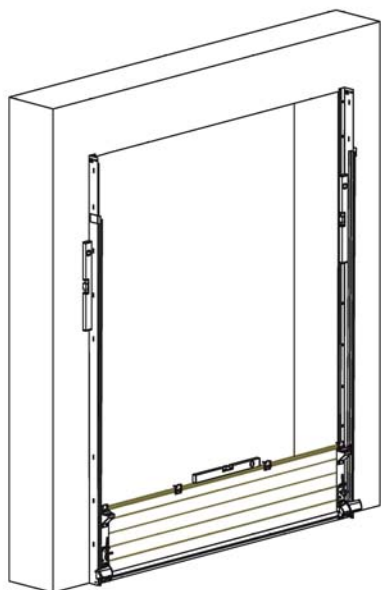

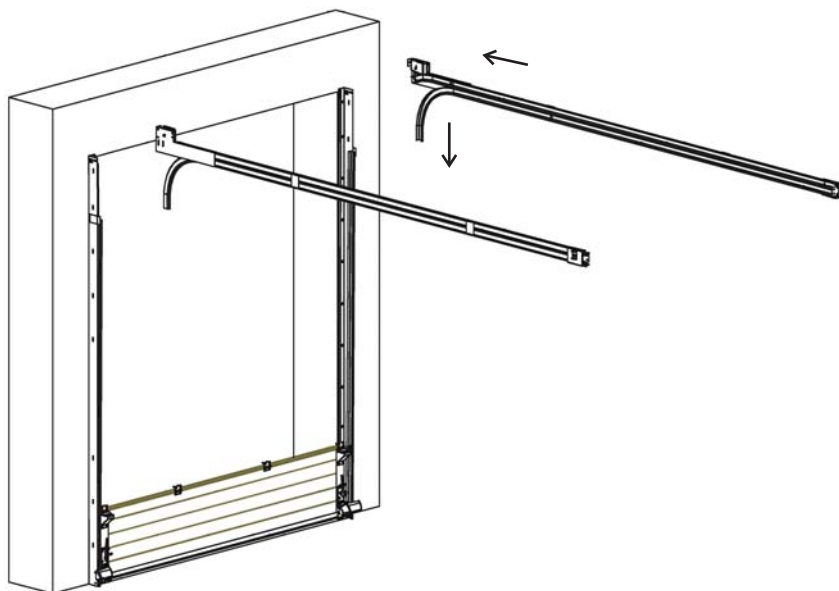
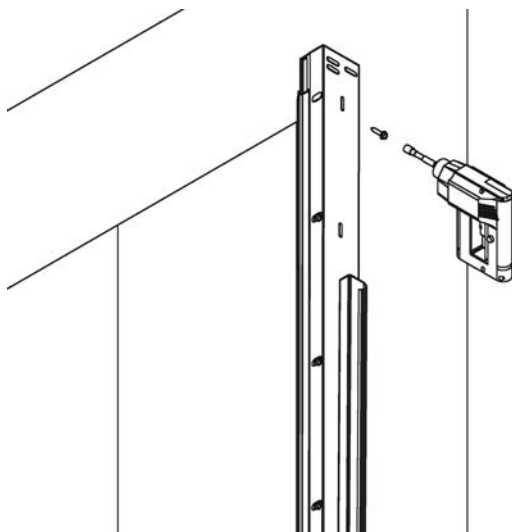
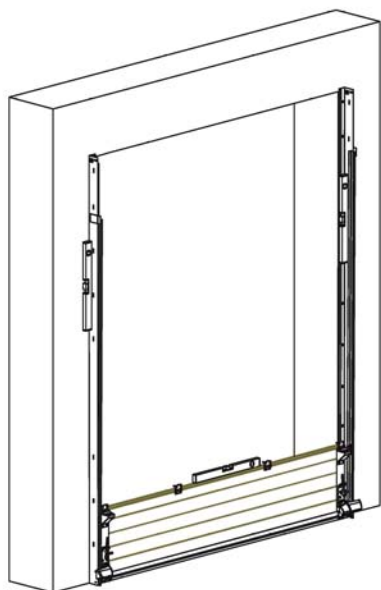

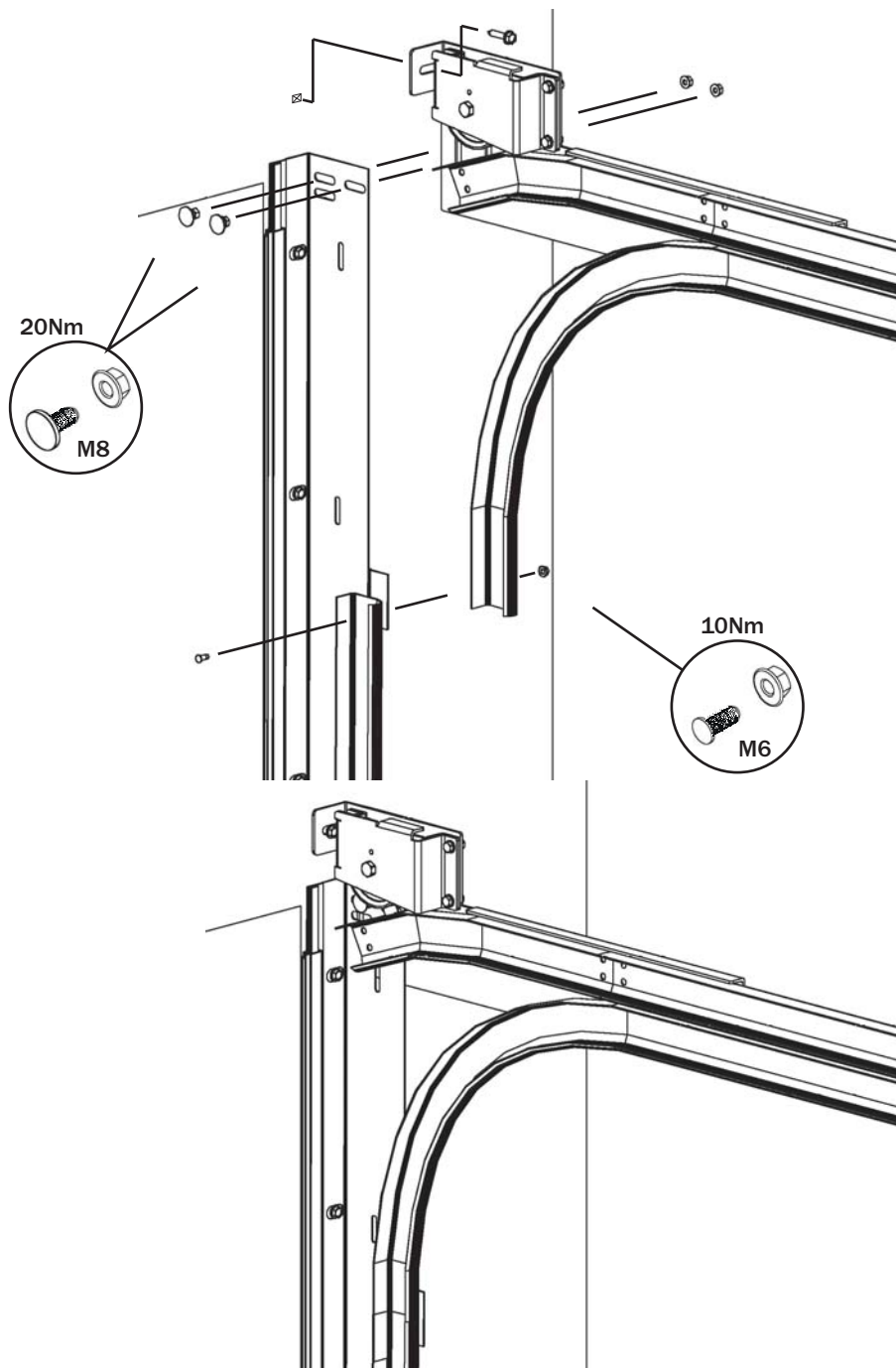

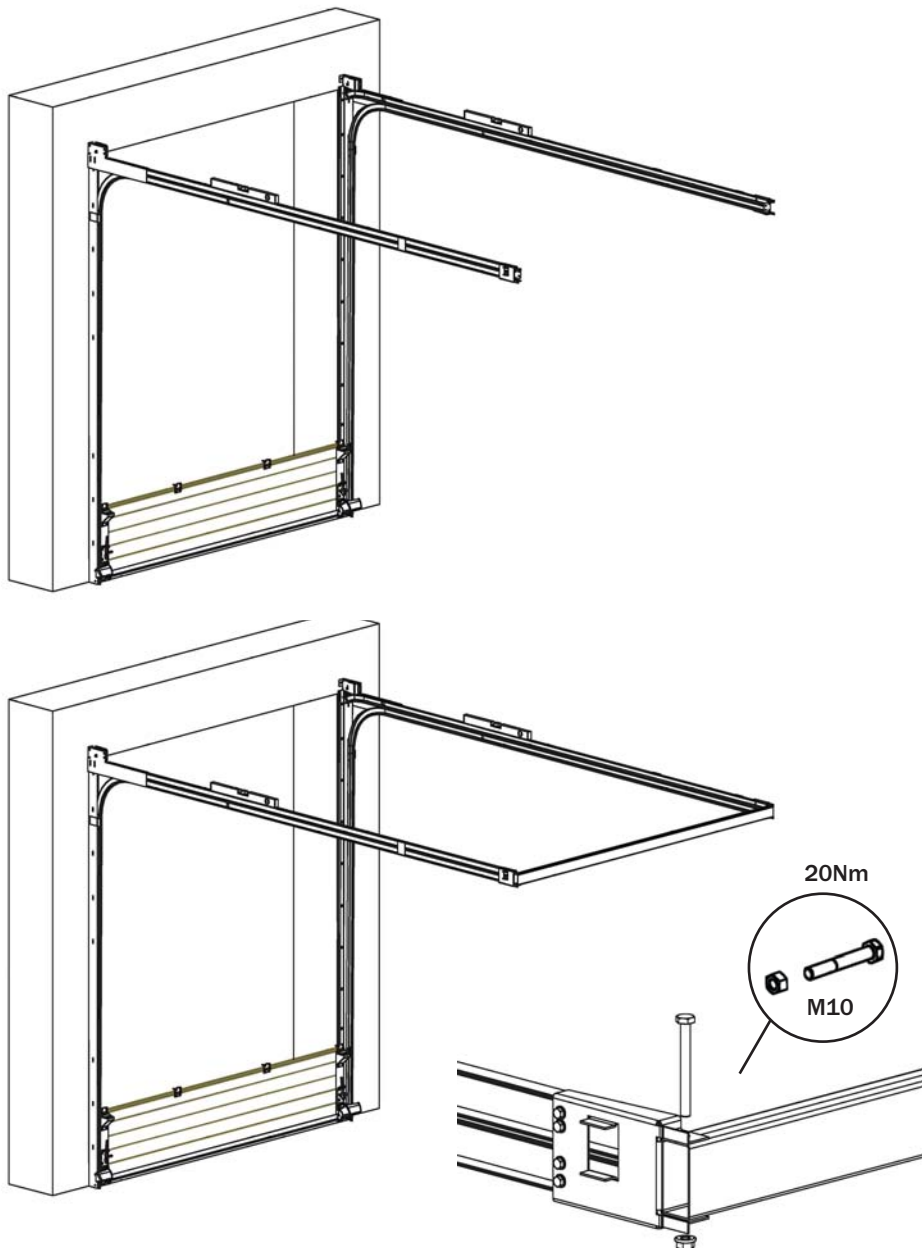

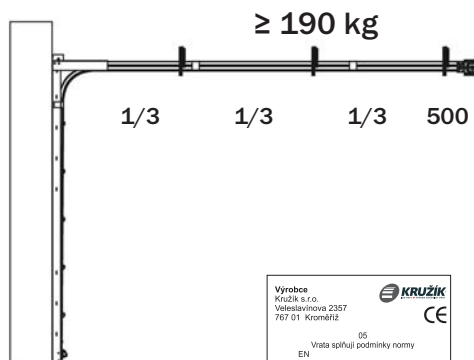
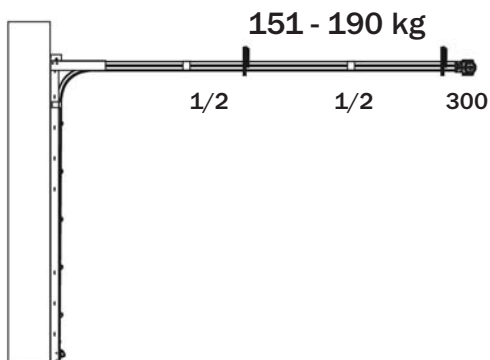
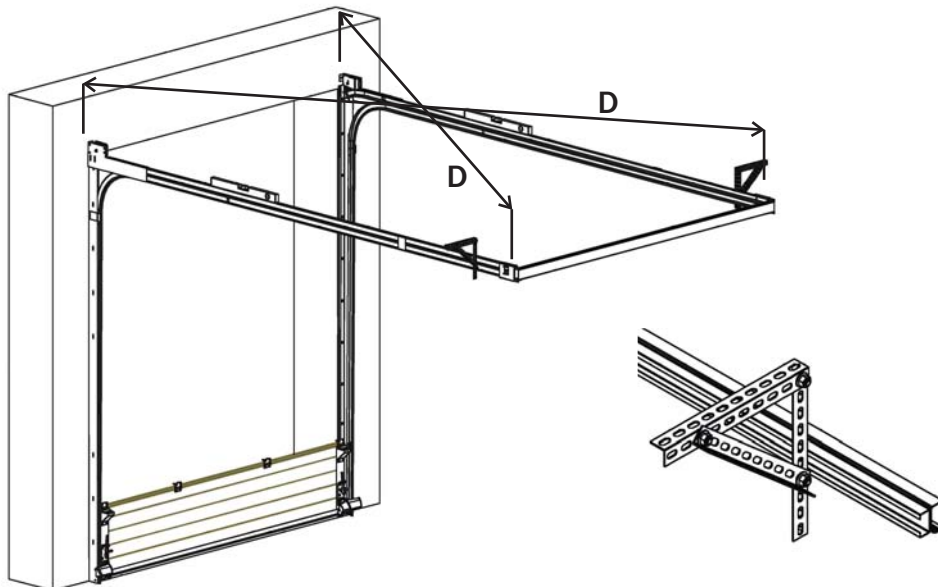

Výrobce
Kružík s. r. o.
Věstecká 2357
767 01 Kroměříž

05
Vrata společný podmínky normy
EN (Směrnice)

SEKČNÍ VRATA

výrobní číslo:	<input checked="" type="checkbox"/>
odolnost proti zatížení větrem:	<input checked="" type="checkbox"/>
soudržnost prostupu tepla:	<input checked="" type="checkbox"/>
průvzdušnost:	<input checked="" type="checkbox"/>
vodotěsnost:	<input checked="" type="checkbox"/>
rok výroby:	<input checked="" type="checkbox"/>
váha vrat:	<input checked="" type="checkbox"/>
orientační počet otáček pružin:	<input checked="" type="checkbox"/>

Zákaz vstupuje při pohybu vrat do pracovního prostoru vrat!
UPOZORNĚNÍ
Každých 6 měsíců kontrolovat:
Navíjecí lanka, navíjecí bubliny, šroubové spoje, pružiny, vyčistění a promazání všech kluzných ploch i ložisek (brzdících pružin, parů, koleček), vyčistění vodících kolejnic.
Při větším rozsahu opravy kontaktujte montážní firmu.

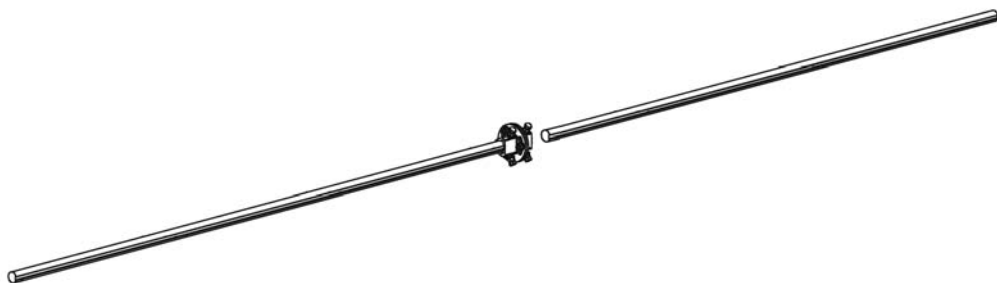
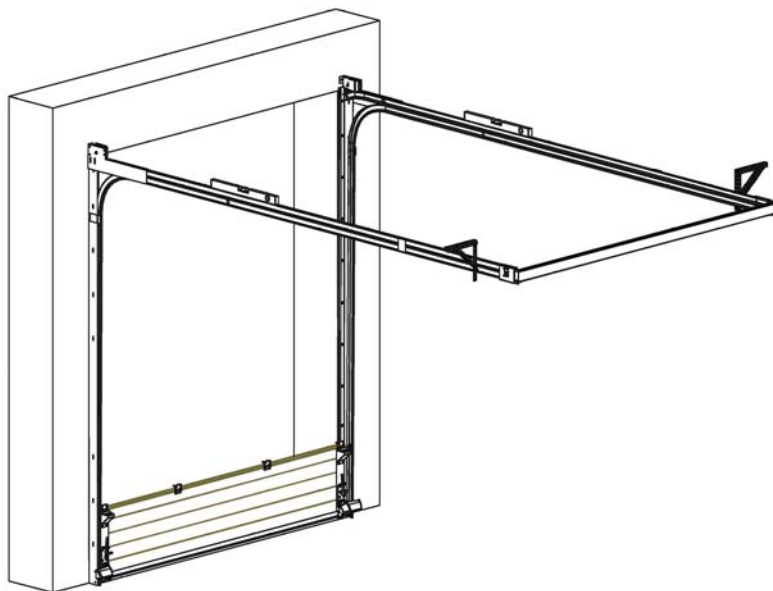

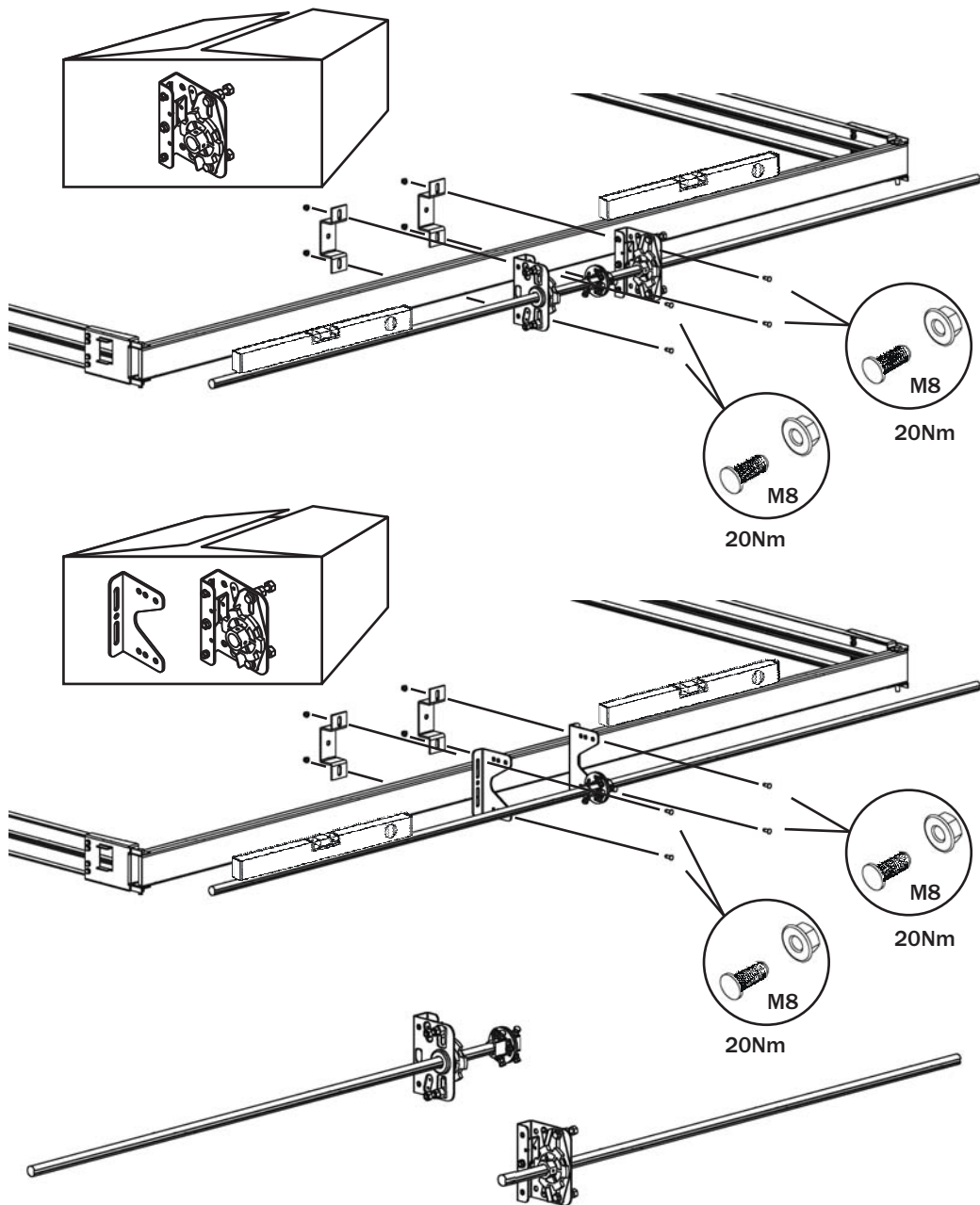

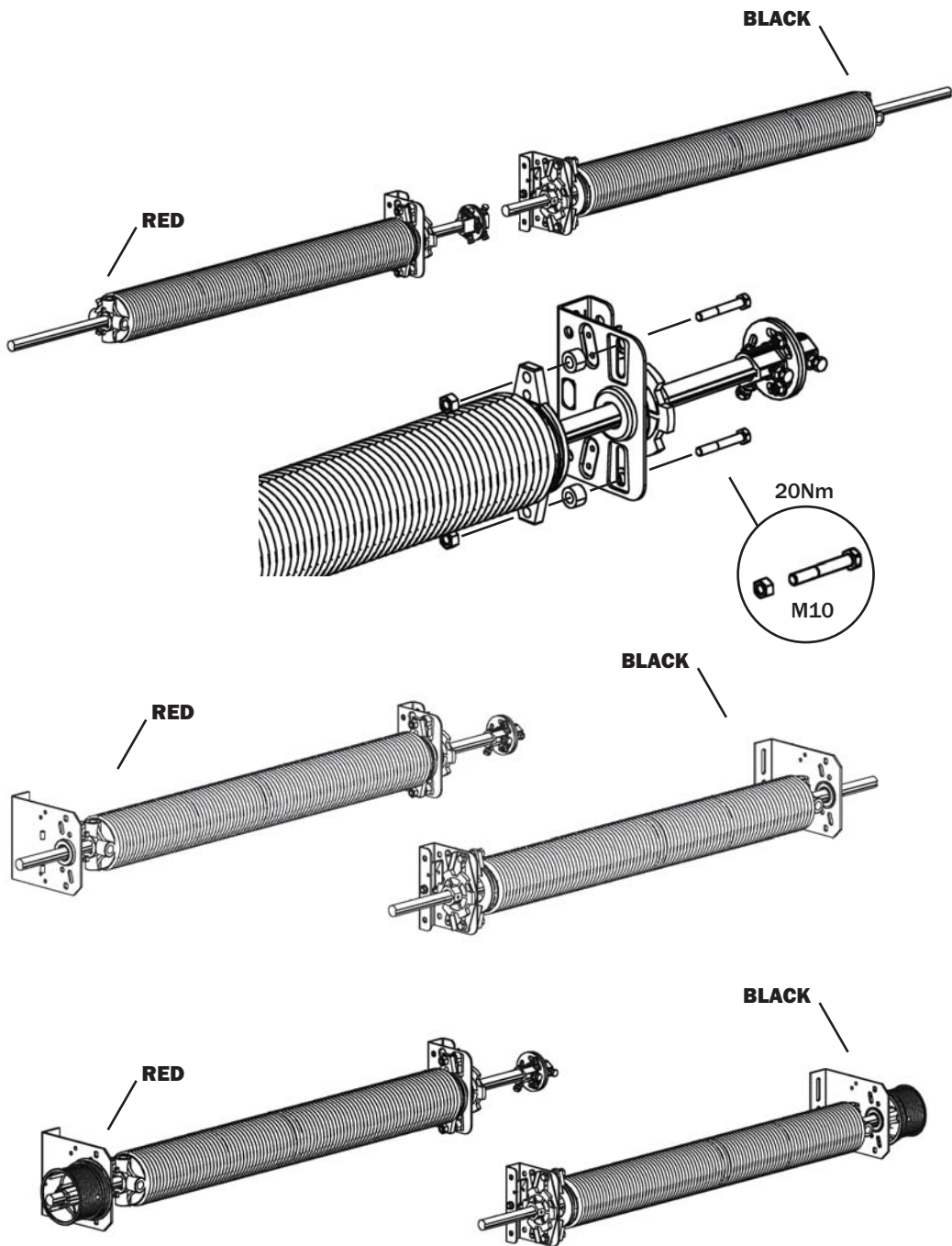

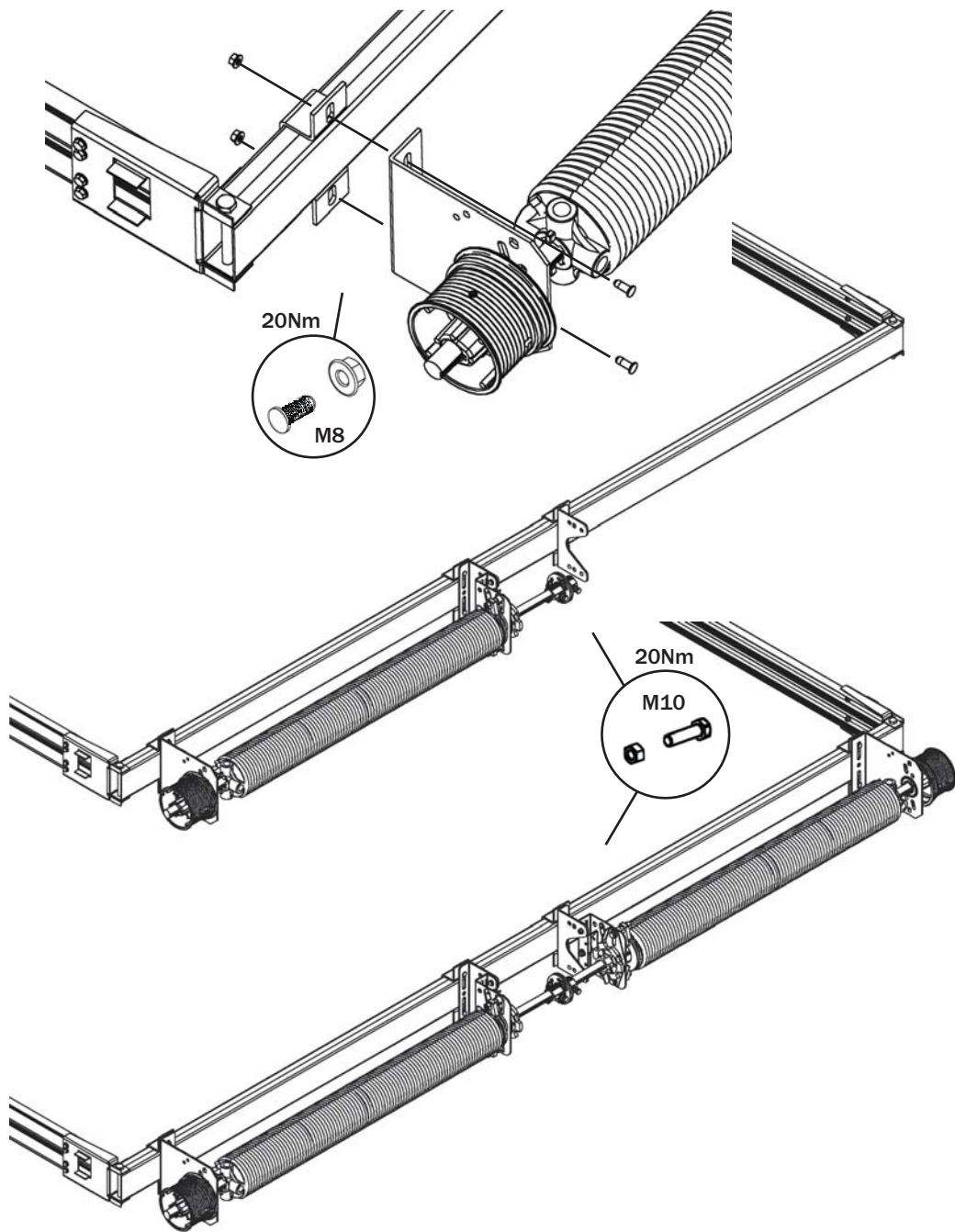

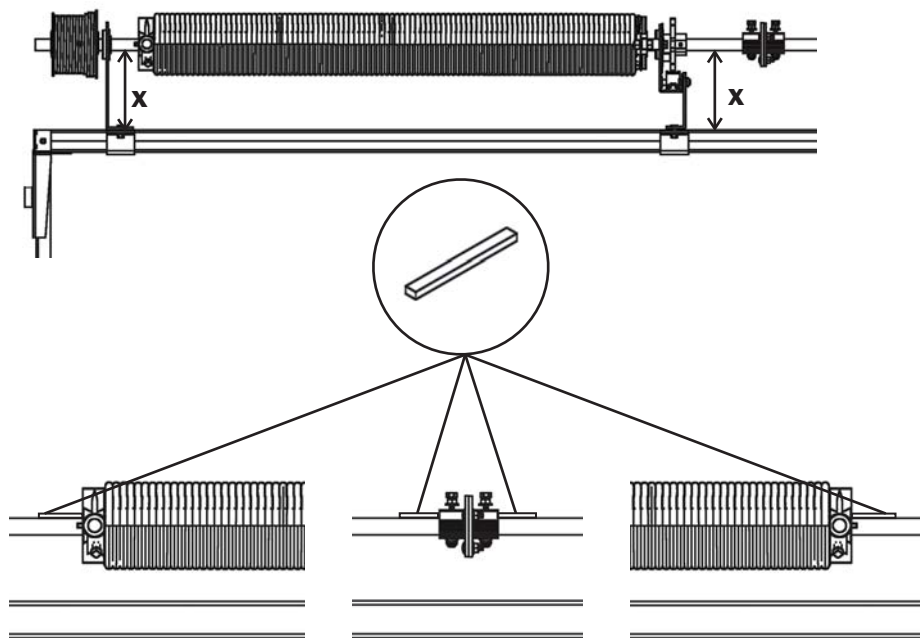
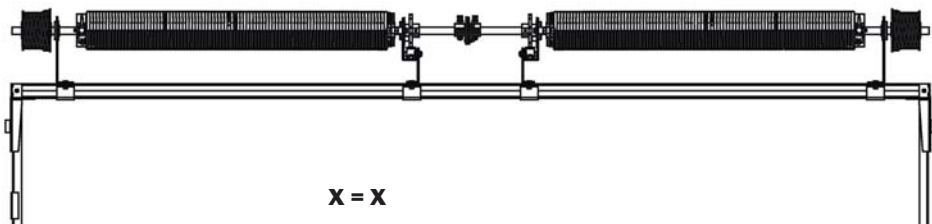

OPTION with 4 torsion springs

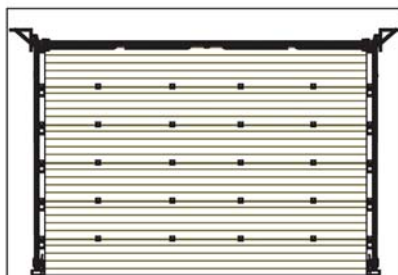

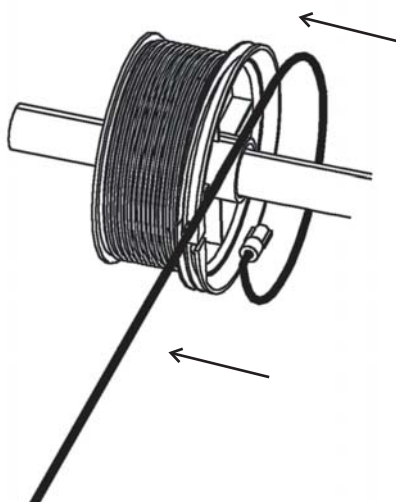
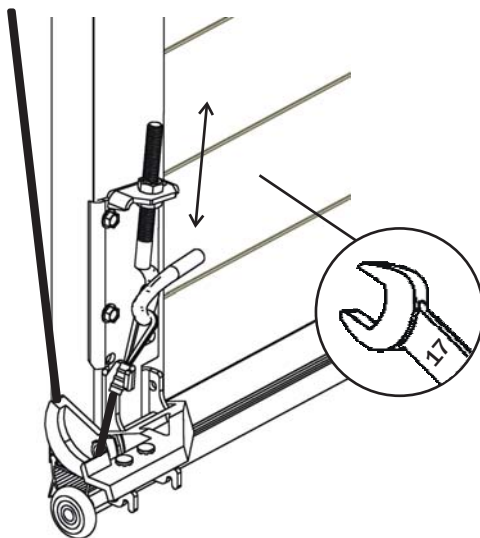

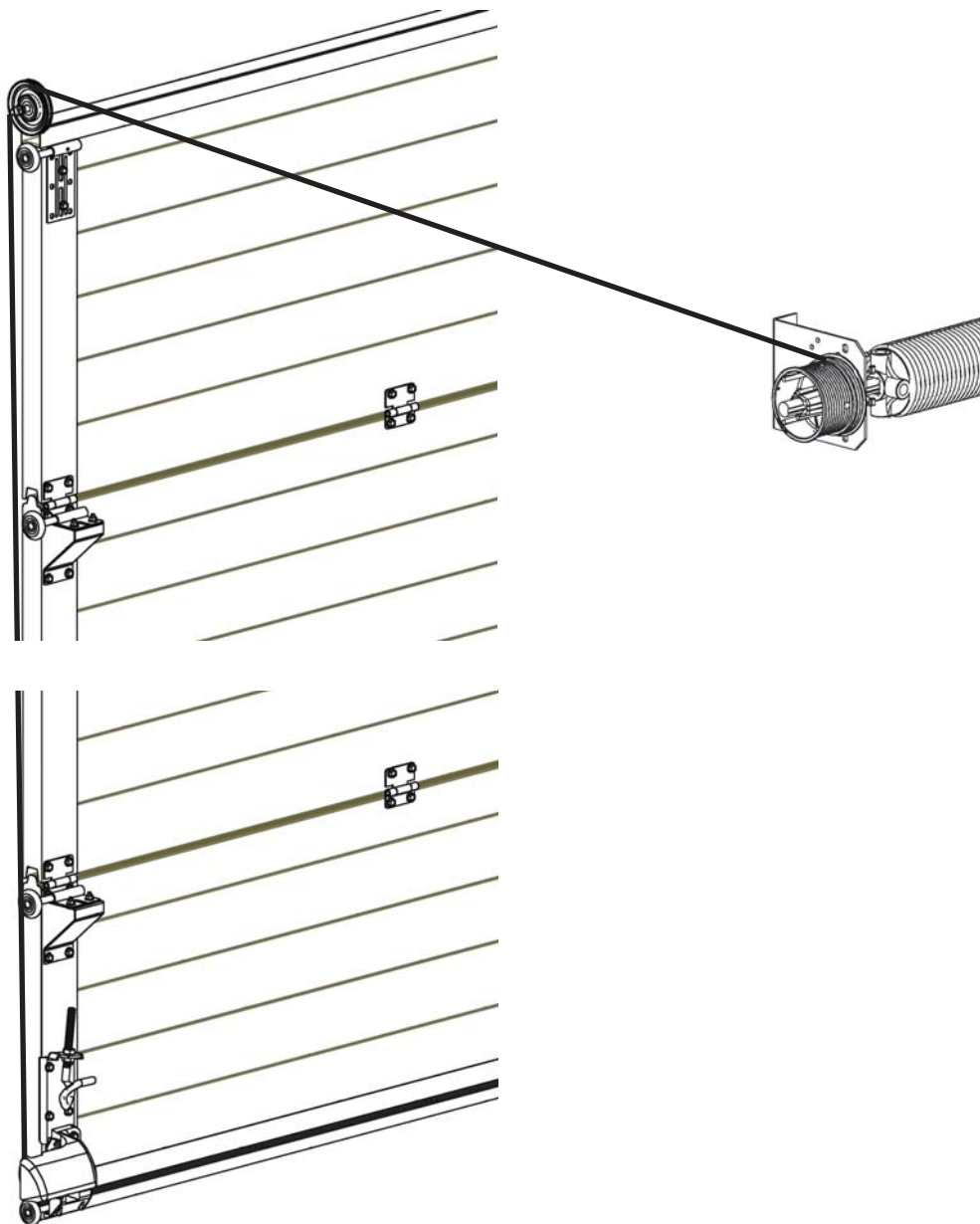

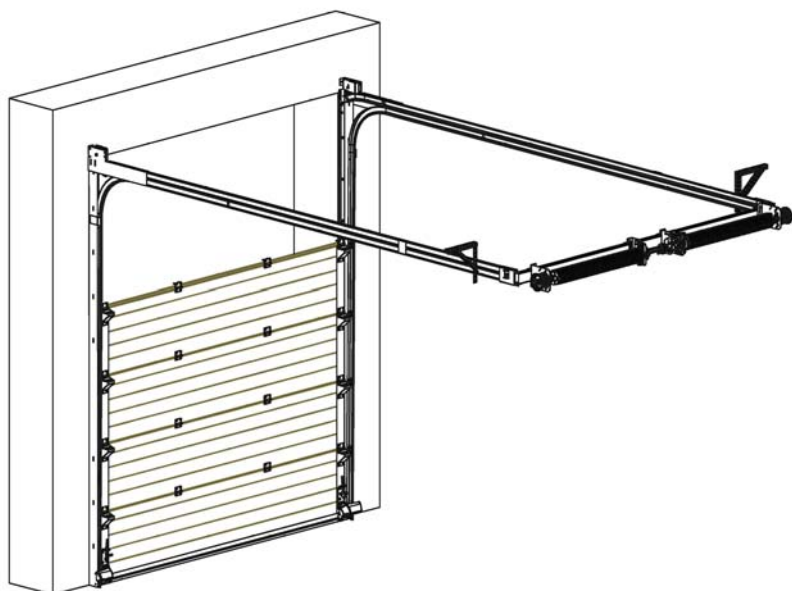
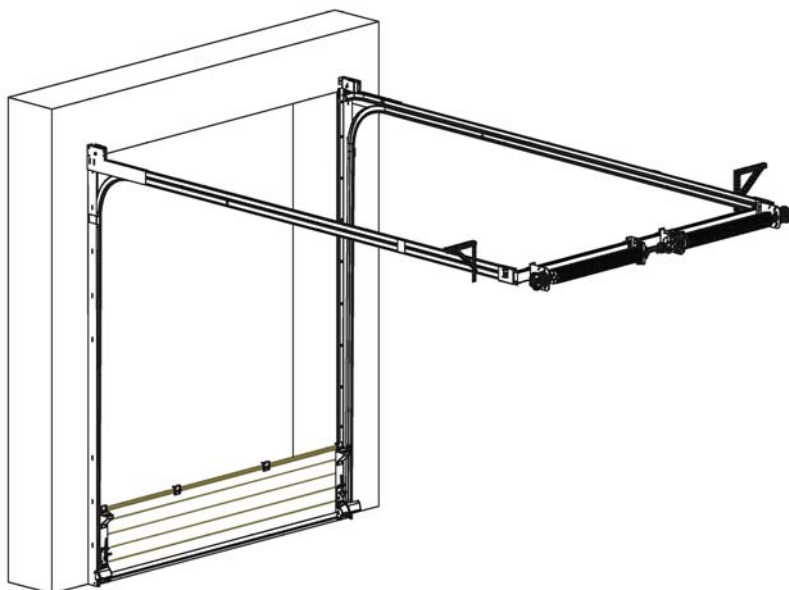

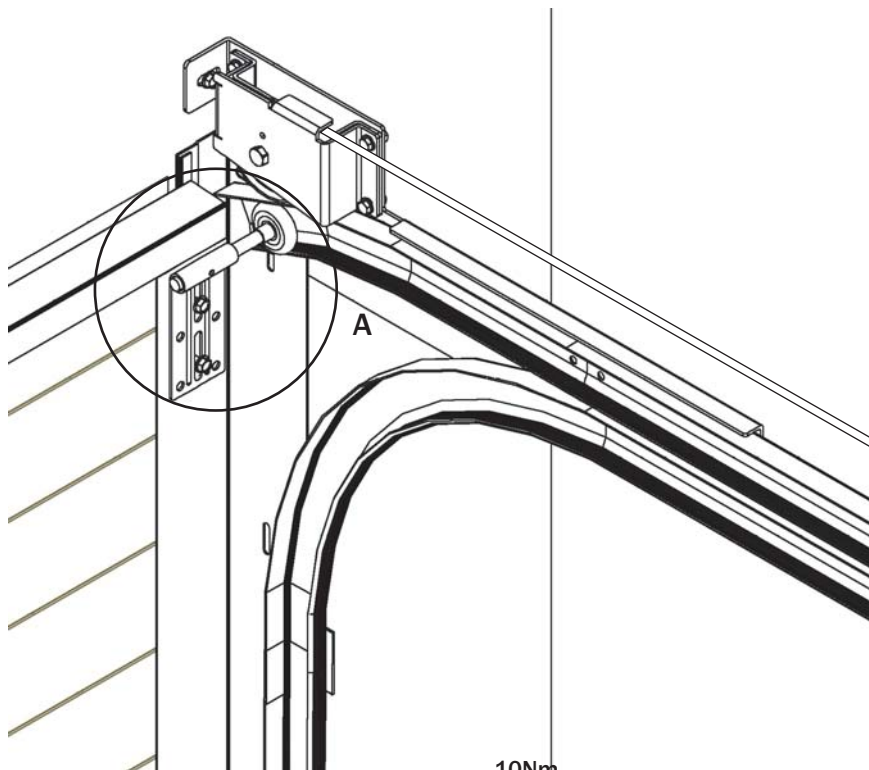

10Nm

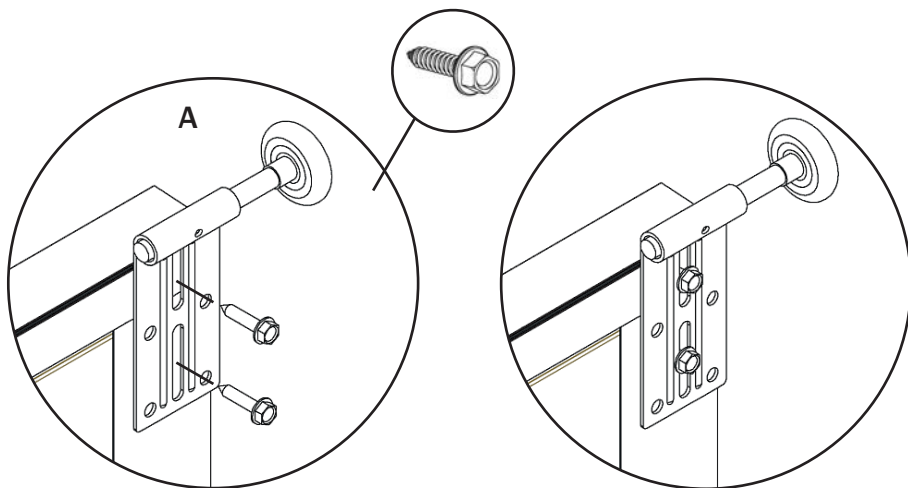

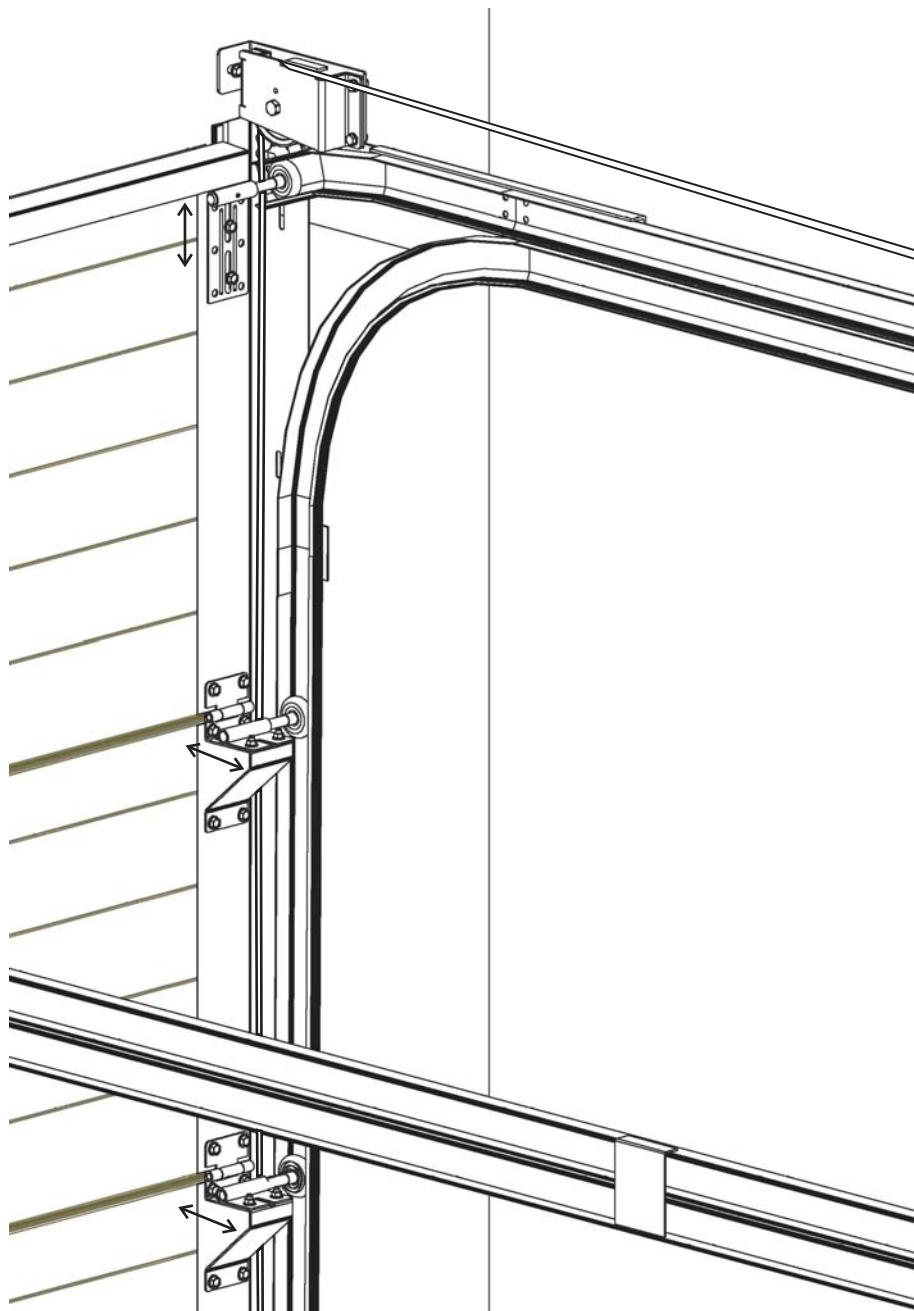

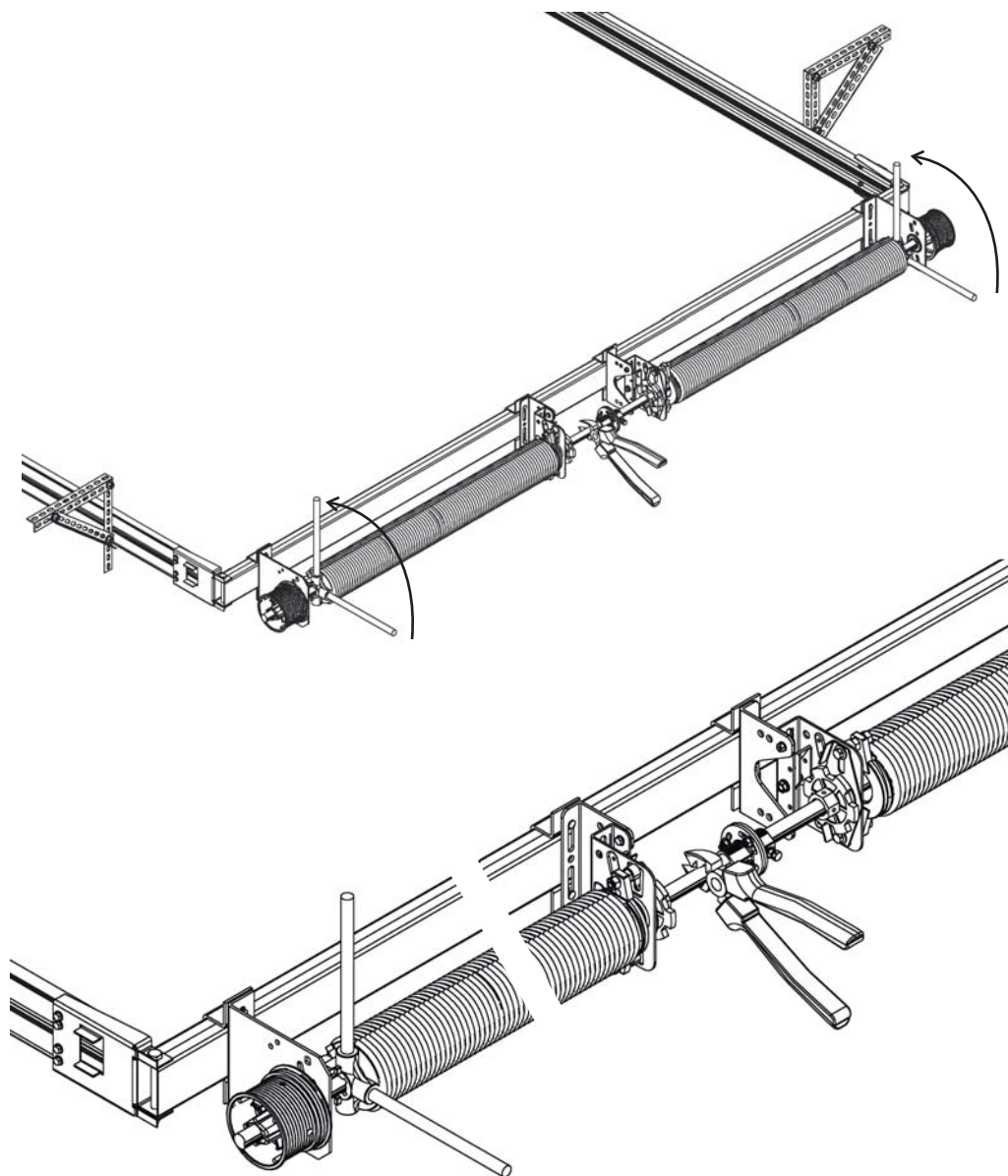

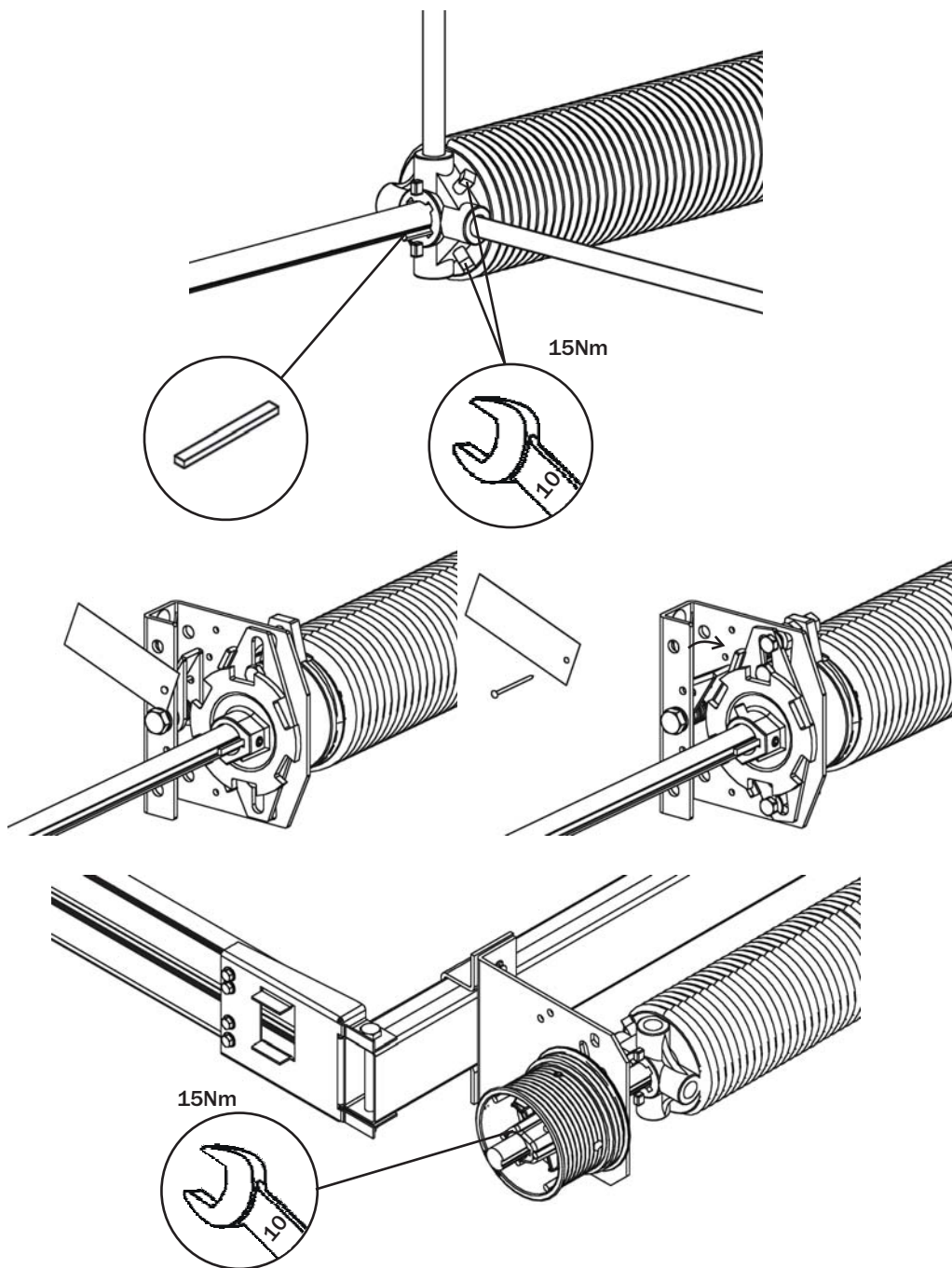

A

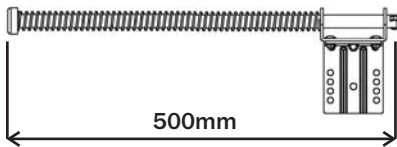

B

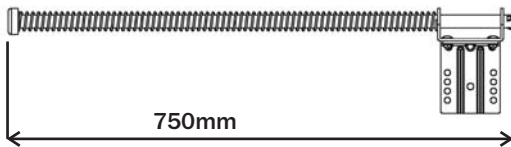

10Nm

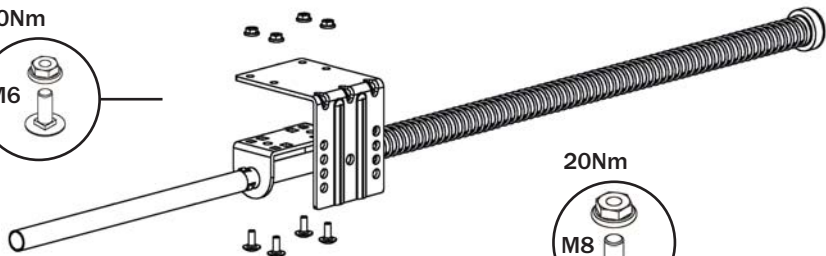

20Nm

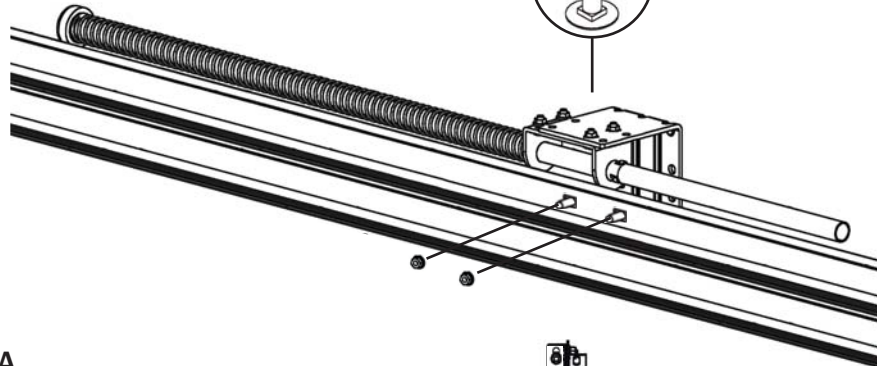

A

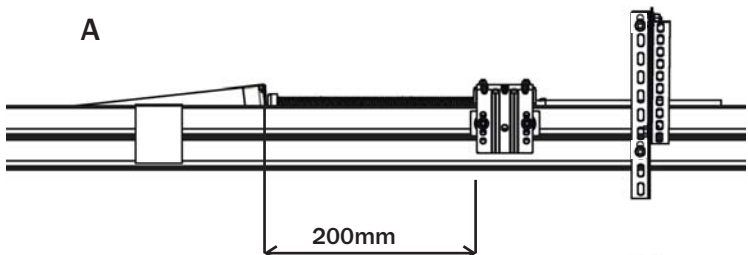

B

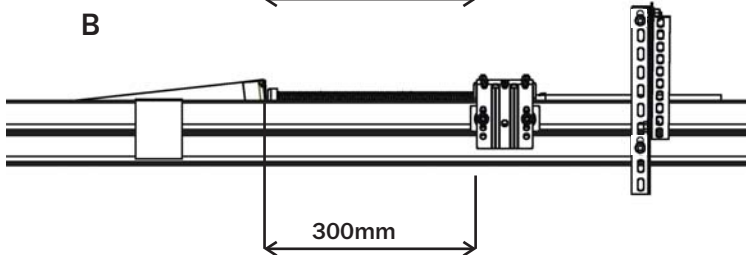

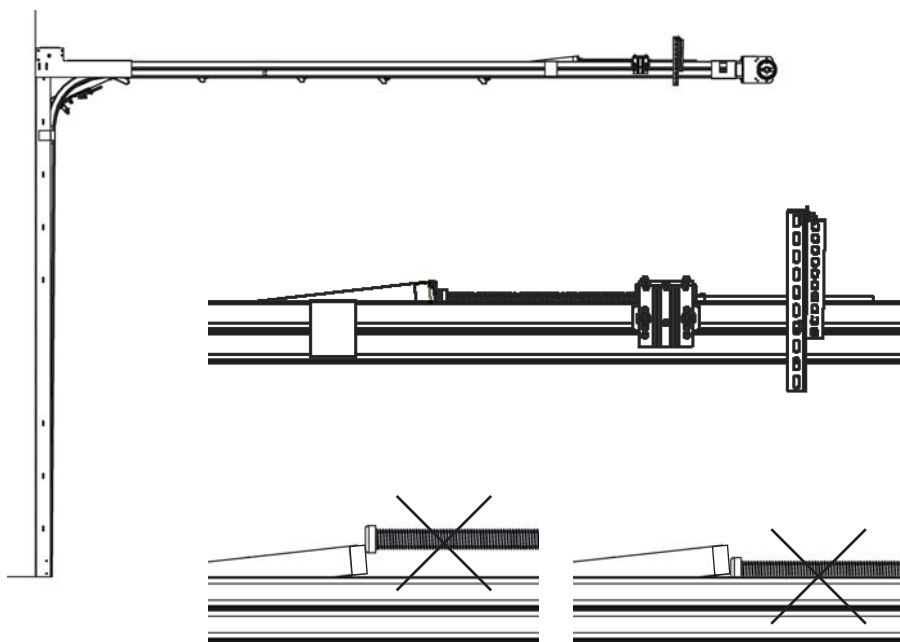
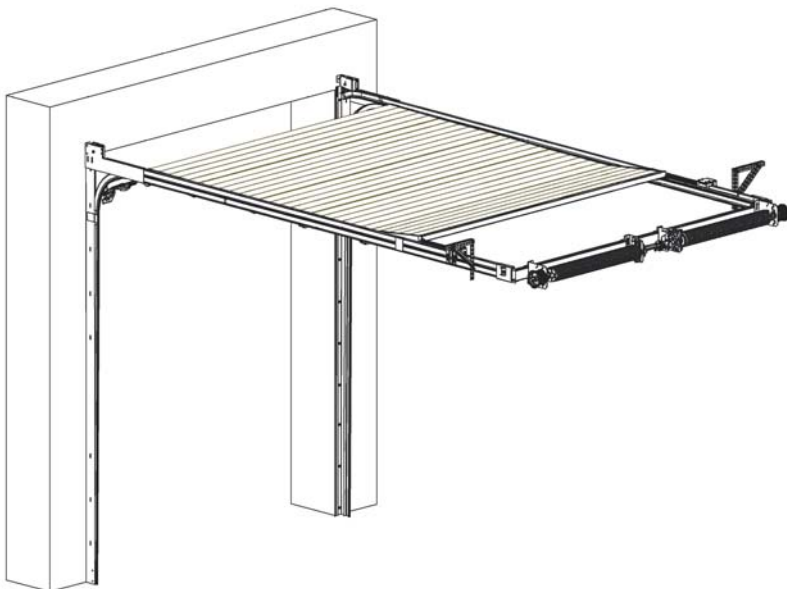

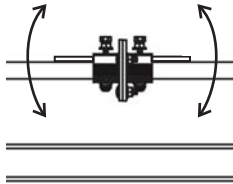
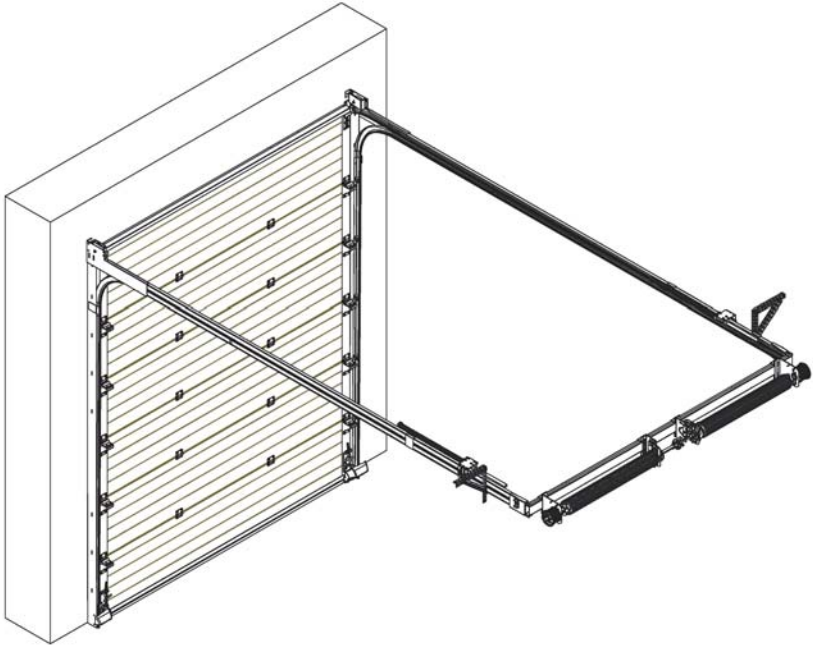

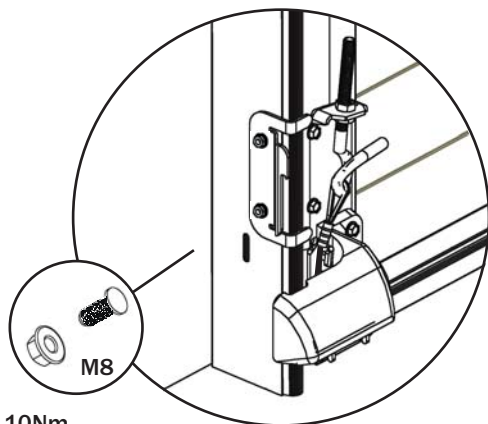
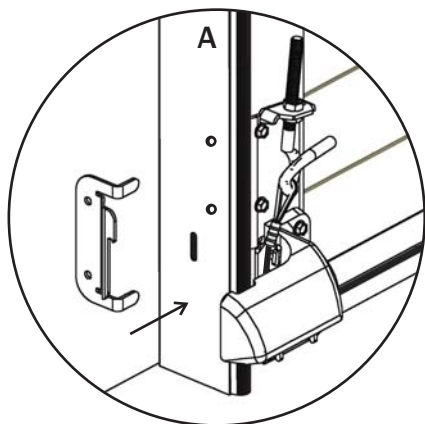
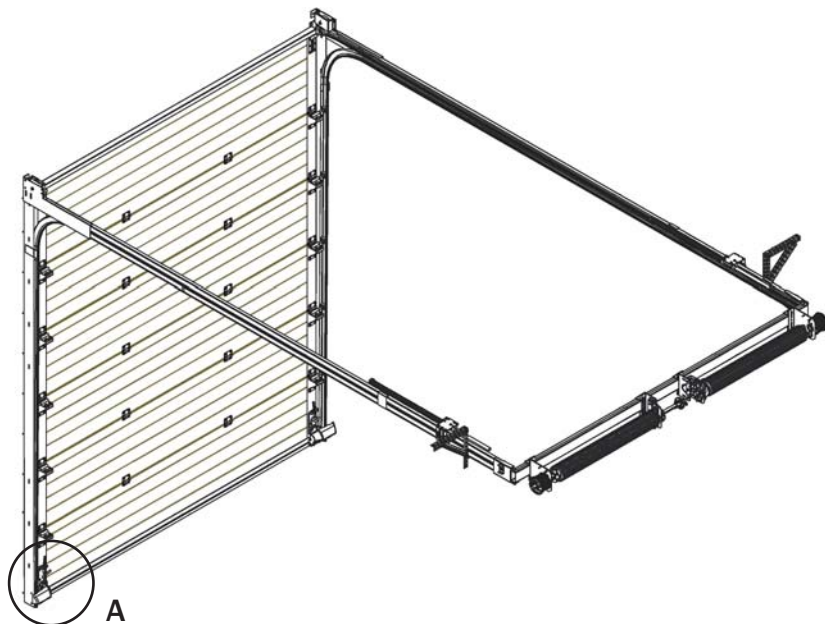

10Nm

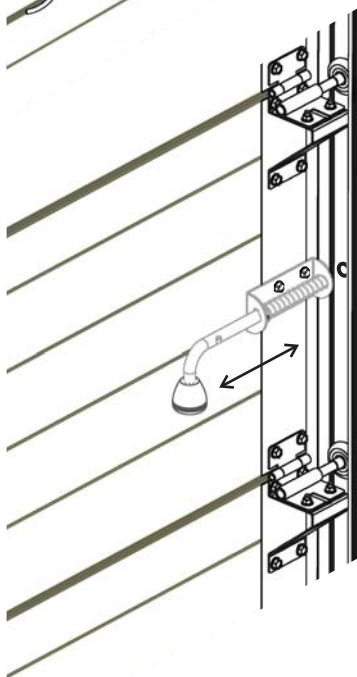
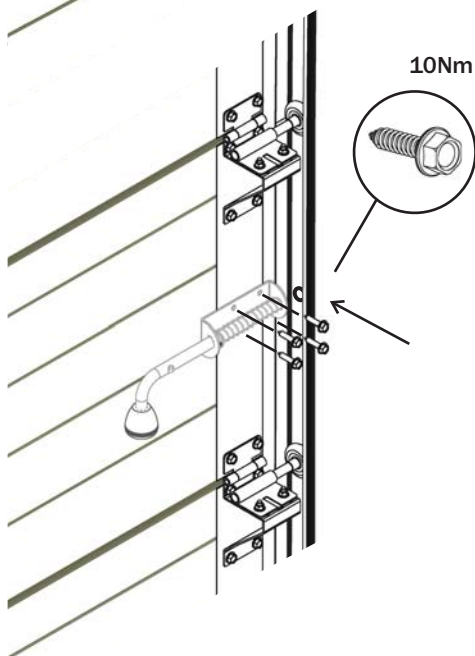
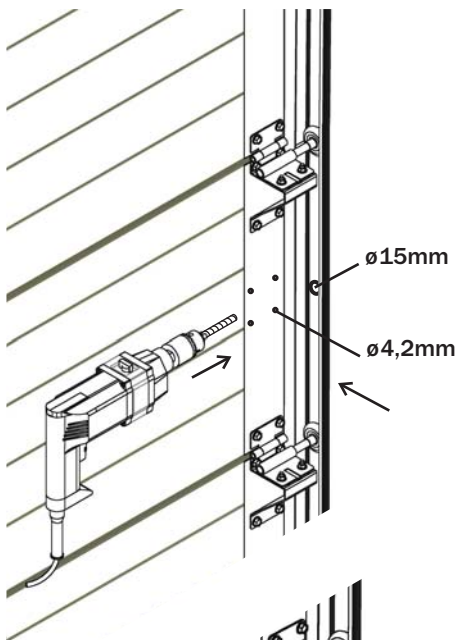
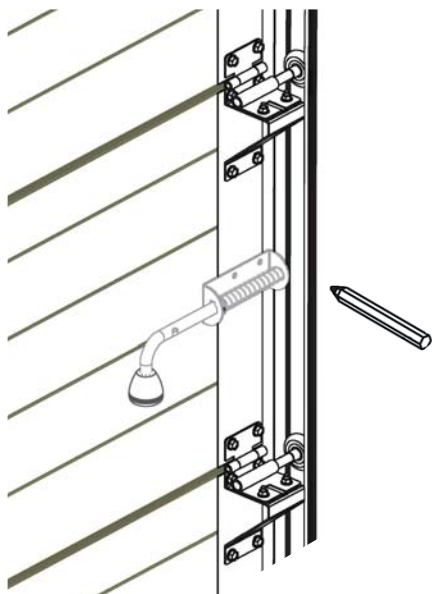

Instructions for demounting of the industrial sectional door

The door has to be in the closed position during demounting!

Release the torsion springs before the start of the demounting works! !!!!

1) Disengagement of the torsion springs

First put the tension rod into the spring head and than disengage release the ensured screw on the torsion spring. Cushion the torsion spring and turn the spring head in its power wise until the spring power stops acting. For spring cushioning of garage doors we need two tension rods with a diameter 16mm.

2) Panel demounting

After the spring disengagement begin to demount the top, middle and side hinges. Begin to demount always from the top panel. After demounting the hinges on the panel remove it immediately. Repeat this procedure for all panels. Unlock the winding wire from the lower panel hinge and also remove this section.

3) Demounting of torsion springs, drums and torsion bars

Disengage the ensured screws on the drums and the ratchet-wheel of spring break protection. Than unscrew the torsion springs from the spring break protections. In case of two shafts demount the coupler. When using an industrial door opener, it has to be demounted from the torsion shaft before removing the shaft. Move the shaft to one side to pull it out of the spring break device. Than take it down from the console.

4) Demounting the console and the spring break device

After demounting the torsion shaft demount the spring break devices and the consoles from the lintel.

5) Demounting the horizontal tracks

Unscrew the perforated mounting profiles from the ceiling and also the screws connecting the horizontal and the vertical tracks.

6) Demounting the vertical tracks

Unscrew the vertical tracks from the door opening.



KRUŽÍK® /

Kroměříž, Veleslavínova 2357, [tel.] 573 336 233, [fax.] 573 343 582
Praha 10 Hostivař, Herbenova 38, [tel.] 267 710 901, [fax.] 267 710 696
г. Мукачево 89622, 000, "Кружик Украина", с. Ивановцы, ул. Мира, 3, [тел] +38-050-523-59-69

19082017

www.kruzik.cz | www.kruzik.com | www.kruzik.com.ua | www.kruzik.eu